

## Porta **precision grade** keyless chucks for CNC machine tools and machining centres with **integral shank**

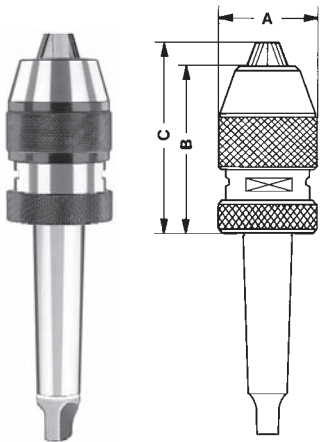

Model No.	Drilling capacity mm	Mount	A mm	B mm	C mm	Packaging style	Weight g
MT08MT2	0-8	2 Morse taper	37	67	74	Individual box	770
MT10MT2	0-10		41	81	89		990
MT13MT2	1-13	2 Morse taper	50,5	88	99		1200
MT13MT3		3 Morse taper					1360
MT13MT4		4 Morse taper					1628
MT13R8		R8 Bridgeport					1435
MT16MT2	3-16	2 Morse taper	56	95	108		1580
MT16MT3		3 Morse taper					1690
MT16MT4		4 Morse taper					1980
MT16R8		R8 Bridgeport					1650