

Porta **precision grade** keyless chucks with **integral shank** for CNC machine tools and machining centres supplied with milled wrench flats and spanner wrench to allow the application of supplementary gripping torque

### DIN 2080

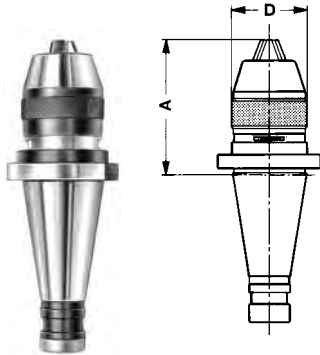

Model No.	Drilling capacity mm	Iso taper size	Drawbolt thread	D mm	A mm min	A mm max	Packaging style	Weight g
MP0840D20	0-8	40	M16	36.50	57	64	Individual box	1005
MP1340D20	1-13	40	M16	48.50	78	90	Individual box	1395
MP1350D20		50	M24		75	87		3155
MP1640D20	3-16	40	M16	54.50	90	102	Individual box	1730
MP1650D20		50	M24		72	84		3295

### DIN 69871 Form A

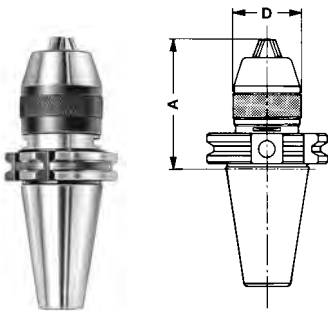

Model No.	Drilling capacity mm	Iso taper size	Drawbolt thread	D mm	A mm min	A mm max	Packaging style	Weight g
MP0840D69A	0-8	40	M16	36.50	64	71	Individual box	1005
MP1340D69A	1-13	40	M16	48.50	80	92	Individual box	1380
MP1350D69A		50	M24		78	90		3170
MP1640D69A	3-16	40	M16	54.50	97	106	Individual box	1780
MP1650D69A		50	M24		76	88		3305

### MAS 403 BT

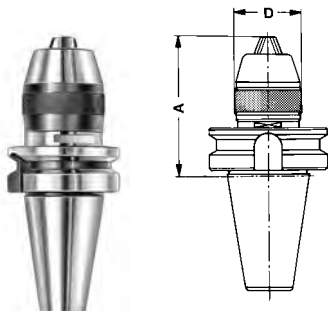

Model No.	Drilling capacity mm	Iso taper size	Drawbolt thread	D mm	A mm min	A mm max	Packaging style	Weight g
MP0830MBT	0-8	30	M12	36.50	77	84	Individual box	695
MP0840MBT		40	M16		72	79		1200
MP1340MBT	1-13	40	M16	48.50	86	98	Individual box	1535
MP1350MBT		50	M24		97	109		4135
MP1640MBT	3-16	40	M16	54.50	105	117	Individual box	1935
MP1650MBT		50	M24		95	107		4275

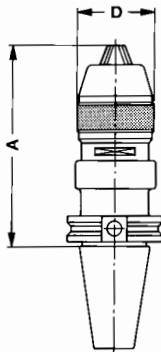

## ANSI CAT

Model No.	Drilling capacity mm	Iso taper size	Drawbolt thread	D mm	A mm		Packaging style	Weight g
					min	max		
MP0840CAT	0-8	40	M16	36.50	82	89	Individual box	1255
MP1340CAT	1-13	40	M16	48.50	115	127	Individual box	1840
MP1350CAT		50	M24		96	108		3650
MP1640CAT	3-16	40	M16	54.50	120	132	Individual box	2230
MP1650CAT		50	M24		94	106		3825